

FINISHED PRODUCT

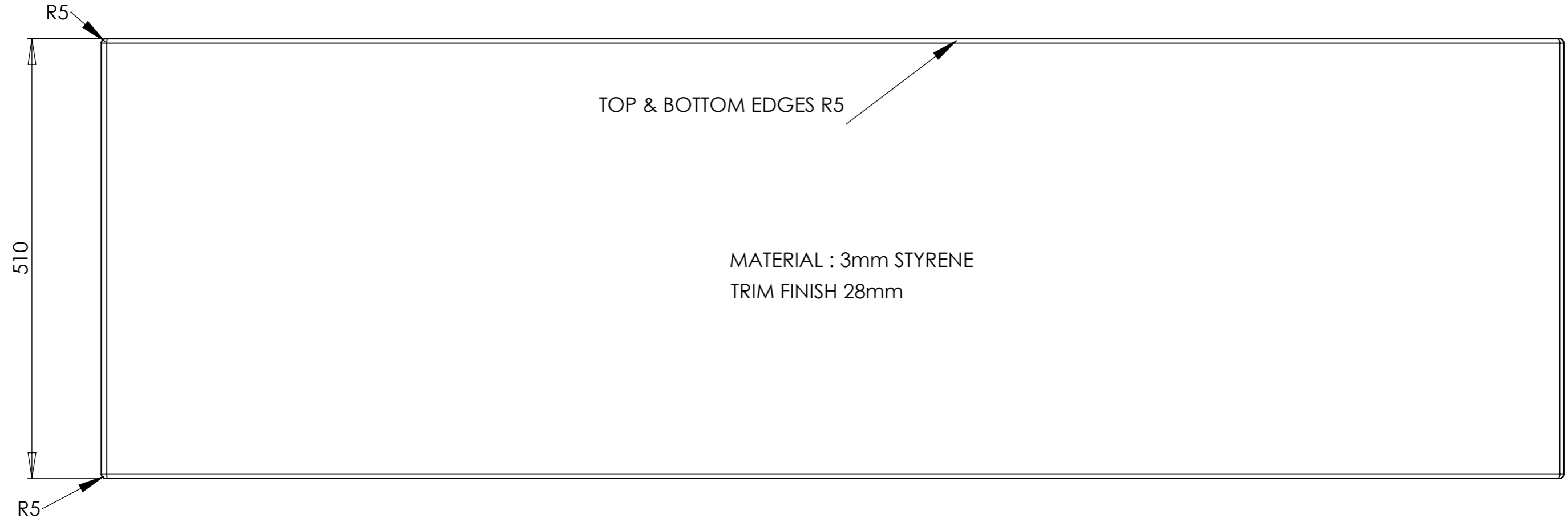

THE INFORMATION CONTAINED IN THIS DRAWING IS THE SOLE PROPERTY OF TROJAN PLASTICS. ANY REPRODUCTION IN PART OR AS A WHOLE WITHOUT THE WRITTEN PERMISSION OF TROJAN PLASTICS IS PROHIBITED.

	NAME	SIGNATURE	DATE	
DRAWN	P.CALLAGHAN		24/05/17	UNLESS OTHERWISE SPECIFIED: DIMENSIONS ARE IN MILLIMETERS SURFACE FINISH: TOLERANCES: ±0.5mm LINEAR: ANGULAR:
CHK'D				
APPV'D				
MFG				
Q.A				
			FINISH:	
			MATERIAL: 3mm Styrene	
			DEBUR AND BREAK SHARP EDGES	
			WEIGHT:	
			DO NOT SCALE DRAWING	REVISION 1

IF IN DOUBT ASK!	FINISH SIZE:
TITLE: SPACE_SAVER_BATH_PANEL	
DWG NO. PD_000073	A4
SCALE	SHEET 1 OF 1