

Simply Silent™ DX100

Technical data

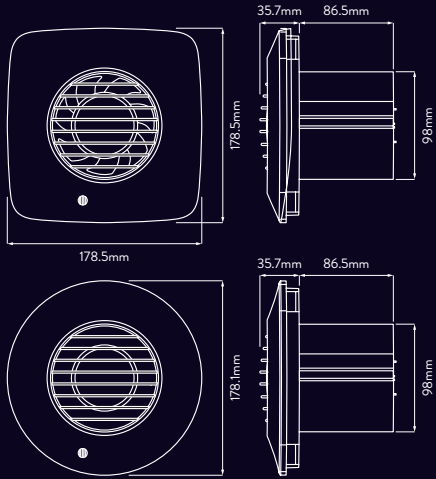

Performance

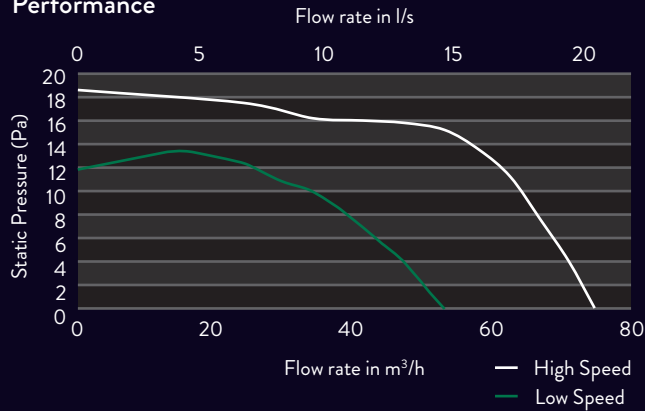

Specification

	DX100
Speeds	2
Extract Performance (l/s)	15/21
Extract Performance (m³/h)	54/76
Electrical Power Rating (W)	6.7/7.7
Specific Fan Power (W/l/s)	0.45/0.37
Sound Pressure Level (dBA@3M)	22/34
IP Rating	X4

Sound pressure testing carried out at ISVR, University of Southampton - March 2015

ISVR Consulting
Consultants in Noise and Vibration

Simply Silent™ DX100

Product information

MODELS

			Design	Timer	Pull cord	Humidistat	PIR	Standard
With Kit	DX100S	93025AW	■					✓
	DX100TS	93026AW	■	✓				
	DX100PS	93027AW	■		✓			
	DX100HTS	93028AW	■	✓		✓		
	DX100HPTS	93029AW	■	✓	✓	✓		
	DX100PIRS	93030AW	■				✓	
	DX100R	93005AW	●					✓
	DX100TR	93006AW	●	✓				
	DX100PR	93007AW	●	✓	✓			
	DX100HTR	93008AW	●	✓		✓		
DX100HPTR	93009AW	●	✓	✓	✓			
DX100PIRR	93010AW	●				✓		
DX100BS	93017AW	■					✓	
DX100BTS	93018AW	■	✓					
DX100BPS	93002AW	■		✓				
DX100BHTS	93019AW	■	✓		✓			
DX100BHPTS	93020AW	■	✓	✓	✓			
DX100BR	92297AW	●					✓	
DX100BTR	92998AW	●	✓					
DX100BPR	93001AW	●	✓	✓				
DX100BHTR	92999AW	●	✓		✓			
DX100BHPTR	93000AW	●	✓	✓	✓			

WALL KIT INCLUDES*



With kit models only.



Technologically advanced.
Contemporary styling.

Simply Silent™ DX100 4"/100mm
Extractor Fan Range.

www.xpelair.co.uk

Sales Hotline: 0844 372 7750

Sales Fax: 0844 372 7760

Xpelair®
AIR QUALITY INNOVATION

X117

GHOST™
AIR MOVEMENT
TECHNOLOGY

Xpelair®
AIR QUALITY INNOVATION

Simply Silent™ DX100

The Simply Silent™ DX two-speed, intermittent extractor fan range is designed for those looking for something conventional, with a modern twist. These fans control humidity, odours and mould growth effectively in bathrooms, shower rooms, cloakrooms and toilets. The Simply Silent™ DX range features a conventional grille-style fascia, finished in cool white and available in either round or square.

Choose a model with or without a wall fitting kit, include a run-on timer that is fully adjustable once installed, a pull cord for on-demand operation, or a timer and built-in humidistat to automatically regulate humidity.

So Simple Installation Fuss-free fitting



Quick-fit clamp.



Radial fixing points and level reference.



Larger cable access.



Screwless hook and clip cover.

The flexible Simply Silent™ DX100 suits wall, ceiling, panel or window installations.

So Simple Installation makes fitting quick and hassle free – wherever it's positioned.

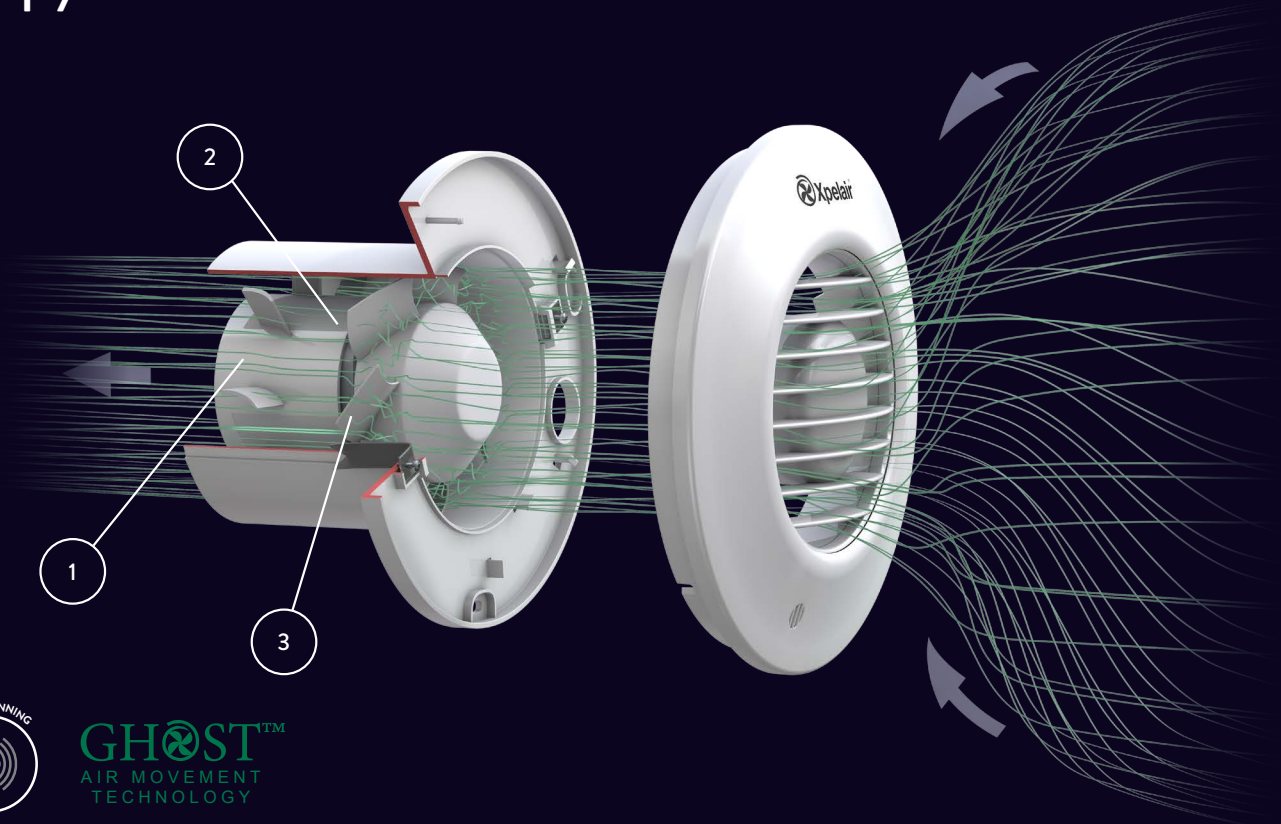

GHØST™
AIR MOVEMENT
TECHNOLOGY

The Simply Silent™ DX100 range of 100mm extract fans features unique, innovative Ghost™ Air Movement Technology to deliver near-silent running.

Fan noise comes from both the motor and the movement of air. To combat this, Ghost™ Air Movement Technology uses long-life silent running motors and precision engineered components to avoid mechanical noise, while advanced air flow management eliminates irregular air flow paths and turbulence.

A look inside

1

Flow straighteners guide air through the duct, **reducing turbulence.**

2

Long-life ball-bearing motors **suppress motor noise.**

3

Optimised impeller blade design **maximises performance, while minimising noise.**