

01.TSRVCR* Corner Thermostatic Radiator Valve Packs

Thermostatic valves are typically used for regulating the fluid flow to the radiators of central heating systems. They are provided with a regulating element which automatically controls the opening of the valve to keep the ambient temperature of the room where they are installed constant at the set value. The number on the valve corresponds to a specific air temperature. Once you have selected a number, the thermostatic valve will maintain this temperature. This prevents unwanted temperature rise and achieves considerable energy savings. The quality is up to the requirement of EN 215/BS7556 standard.

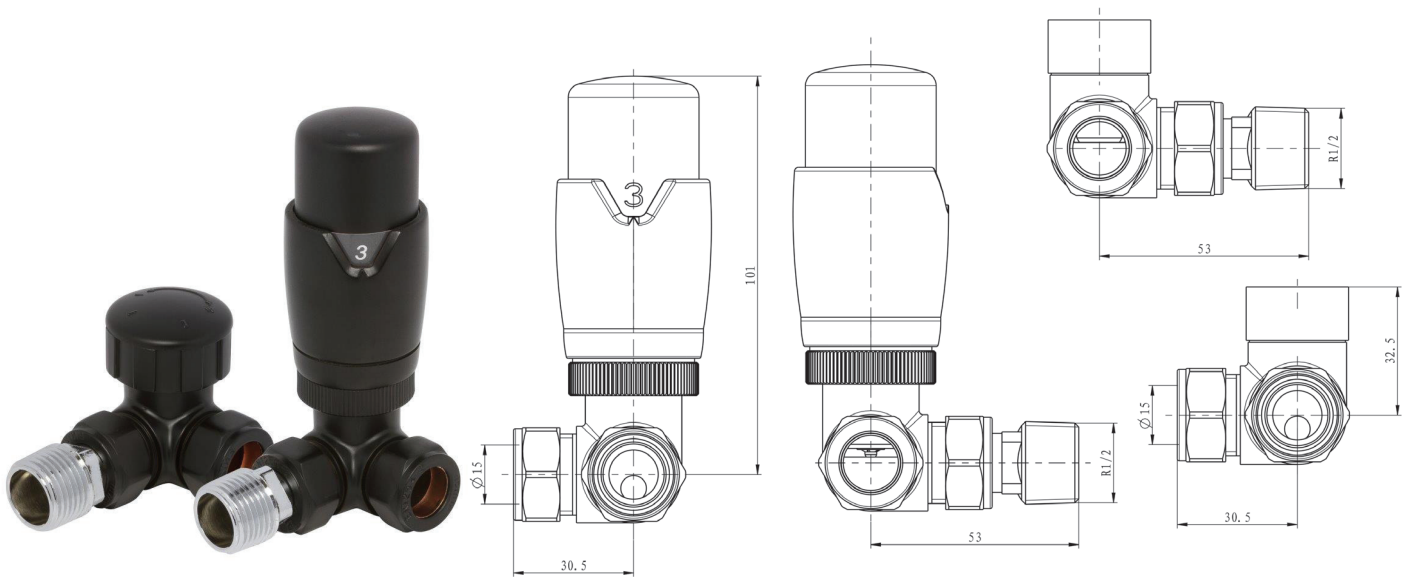

TECHNICAL SPECIFICATION:

- With thermostatic head and reversible bi-directional body.
- Built-in sensor with liquid-filled element
- Fully tested to 10 bar
- 2 year guarantee
- Max pressure difference: 0.8 bar
- Nominal flow rate 173kgs/h
- Max flow temperature 120°C
- Can be mounted horizontally or vertically
- Weight 0.60kg

Graduated scale from 0 to 5 corresponding to temperature setting ranges from 7°C – 29°C with frost protection setting as well (as per figure below)

*	1	2	3	4	5
7°C	11°C – 13°C	15°C - 17°C	19°C - 21°C	23°C - 25°C	27°C - 29°C

Finishes	Chrome	Anthracite	Black	White	Brushed Nickel
Codes	01.TSRVCR	01.TSRVCRA	01.TSRVCRB	01.TSRVCRW	01.TSRVCRBN
Finishes	Brushed Brass				
Codes	01.TSRVCRBN				