

Note 1:
Inside all tapping:
-No burr
-No paint

Note 2:
No burr and any sharp edge on part surface.
Refer to DIN 2768/M for unspecified tolerances.
No any deformation on visible surface after bending.

Note 3:
For 1600 mm product: 0.00506 kg of paste will be used.
For 1400 mm product: 0.00460 kg of paste will be used.
For 1200 mm product: 0.00391 kg of paste will be used.
For 1000 mm product: 0.00299 kg of paste will be used.
For 800 mm product: 0.00230 kg of paste will be used.

INDEX	DESIGNATION	I	L	Surface Roughness
A	Frame Silea Straight Raw 600x400	350	400	For Chrome Coating Maximum Surface Roughness: 0.4 µm For Paint Maximum Surface Roughness: 1.2 µm
B	FRAME SILEA STRAIGHT RAW 800X400	350	400	
A	Frame Silea Straight Raw 800x450	400	450	
B	Frame Silea Straight Raw 800x500	450	500	
A	Frame Silea Straight Raw 800x550	500	550	
B	Frame Silea Straight Raw 800x600	550	600	
B	FRAME SILEA STRAIGHT RAW 1000X400	350	400	
B	Frame Silea Straight Raw 1000x500	450	500	
B	Frame Silea Straight Raw 1000x600	550	600	
A	Frame Silea Straight Raw 1000x1000	950	1000	
B	FRAME SILEA STRAIGHT RAW 1200X400	350	400	
A	Frame Silea Straight Raw 1200x450	400	450	
B	Frame Silea Straight Raw 1200x500	450	500	
A	Frame Silea Straight Raw 1200x550	500	550	
B	Frame Silea Straight Raw 1200x600	550	600	
A	Frame Silea Straight Raw 1200x1000	950	1000	
A	FRAME SILEA STRAIGHT RAW 1400X450	400	450	
A	Frame Silea Straight Raw 1400x500	450	500	
A	Frame Silea Straight Raw 1400x550	500	550	
A	Frame Silea Straight Raw 1400x600	550	600	
B	FRAME SILEA STRAIGHT RAW 1600X400	350	400	
A	Frame Silea Straight Raw 1600x450	400	450	
B	Frame Silea Straight Raw 1600x500	450	500	
A	Frame Silea Straight Raw 1600x550	500	550	
B	Frame Silea Straight Raw 1600x600	550	600	
A	Frame Silea Straight Raw 1800x400	350	400	
A	Frame Silea Straight Raw 1800x500	450	500	
A	Frame Silea Straight Raw 1800x600	550	600	

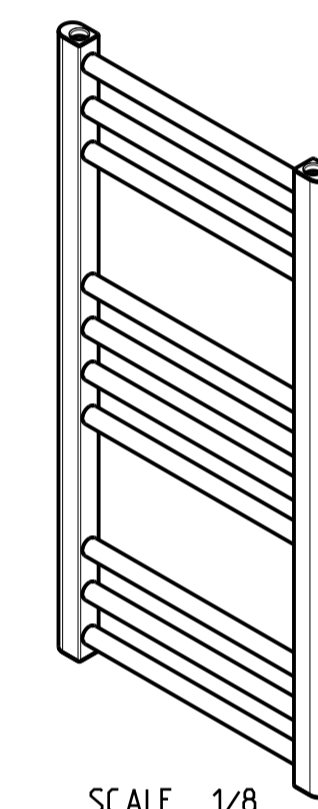

Ind	Date	Modification	Modif/Demand	Modif by
		Weight:	Material:	
Code: SILEA DR RANGE		drawn by stgizmr	checked by	status
creation date	SILEA dritto - gamma SILEA straight - range SILEA gerade - Auswahl			ERP ID
size A2	scale 1/5		PLM ID	folio 1 / 1
				REV. C

This drawing can't be, without authorization, neither copied, neither reproduced, or communicated to third. Law of July 14, 1909 on the drawings and the models.